



## A Micrometric 12-40 KMC Waveguide Slotted Line with Interchangeable Sections and Untuned Probe

HEWLETT-PACKARD slotted lines have always exhibited in their design approach an excellence which has made them the standard of the field. In coaxial equipment, for example, the -hp- 500-4,000 mega-

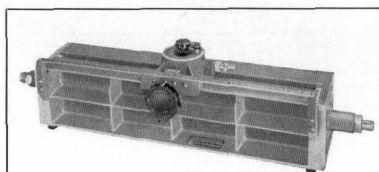

Fig. 1. -hp- Model 805A 500-4,000 mc coaxial slotted section.

cycle slotted section<sup>1</sup> achieved superior performance through the use of two parallel metal planes or slabs.

These served as the outer conductor and gave the section very high mechanical rigidity. In waveguide equipment, the -hp- 4-18 kmc sections<sup>2</sup> were designed so that a single probe carriage could accommodate a number of guide sizes, thereby making one precision probe carriage useful for four or five

waveguide ranges with consequent economy of instrumentation.

A new series of waveguide slotted line equipment has now been designed for the range from 12.4 to 40 kilomegacycles. Like the 4 to 18 kmc sections, the new sections are also designed with

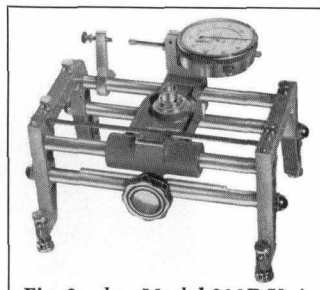

Fig. 2. -hp- Model 809B Universal Probe Carriage for 4-18 kmc waveguide sections.

a single probe carriage which will accommodate any of the three guide sizes that cover the 12-40 kmc range. The design is such that

<sup>1</sup>W. B. Wholey, *Greater Reliability in UHF Impedance Measurements*, Hewlett-Packard Journal, Vol. 1, No. 5, January, 1950.

<sup>2</sup>N. B. Schrock, *The -hp- Program for Waveguide Type Measuring Equipment*, Hewlett-Packard Journal, Vol. 2, No. 6, February, 1951.

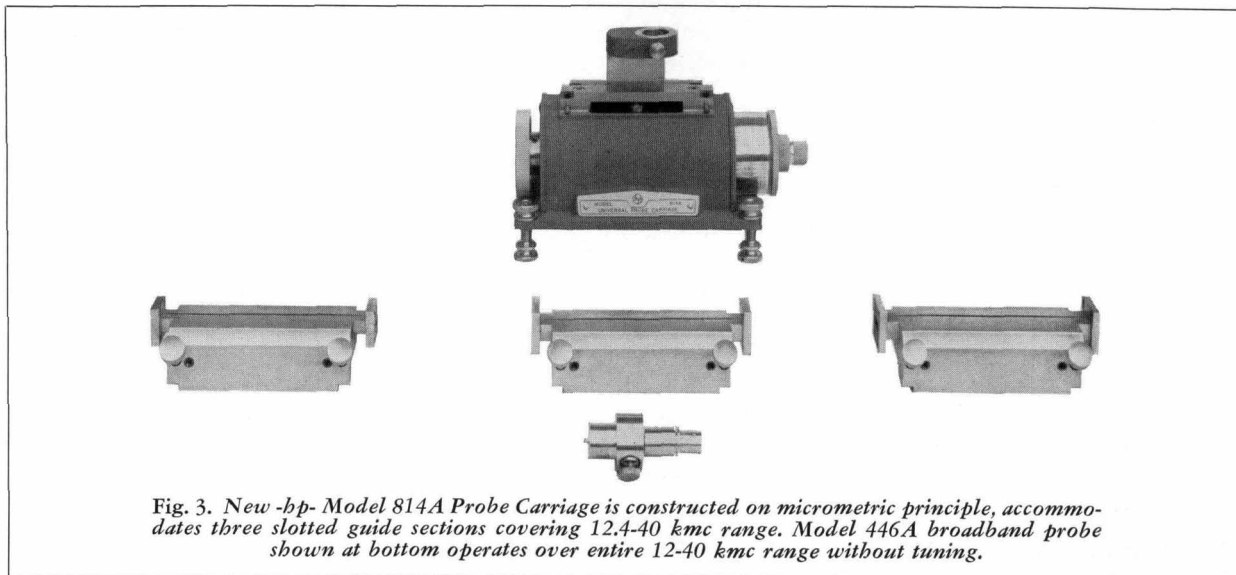

Fig. 3. New -hp- Model 814A Probe Carriage is constructed on micrometric principle, accommodates three slotted guide sections covering 12.4-40 kmc range. Model 446A broadband probe shown at bottom operates over entire 12-40 kmc range without tuning.

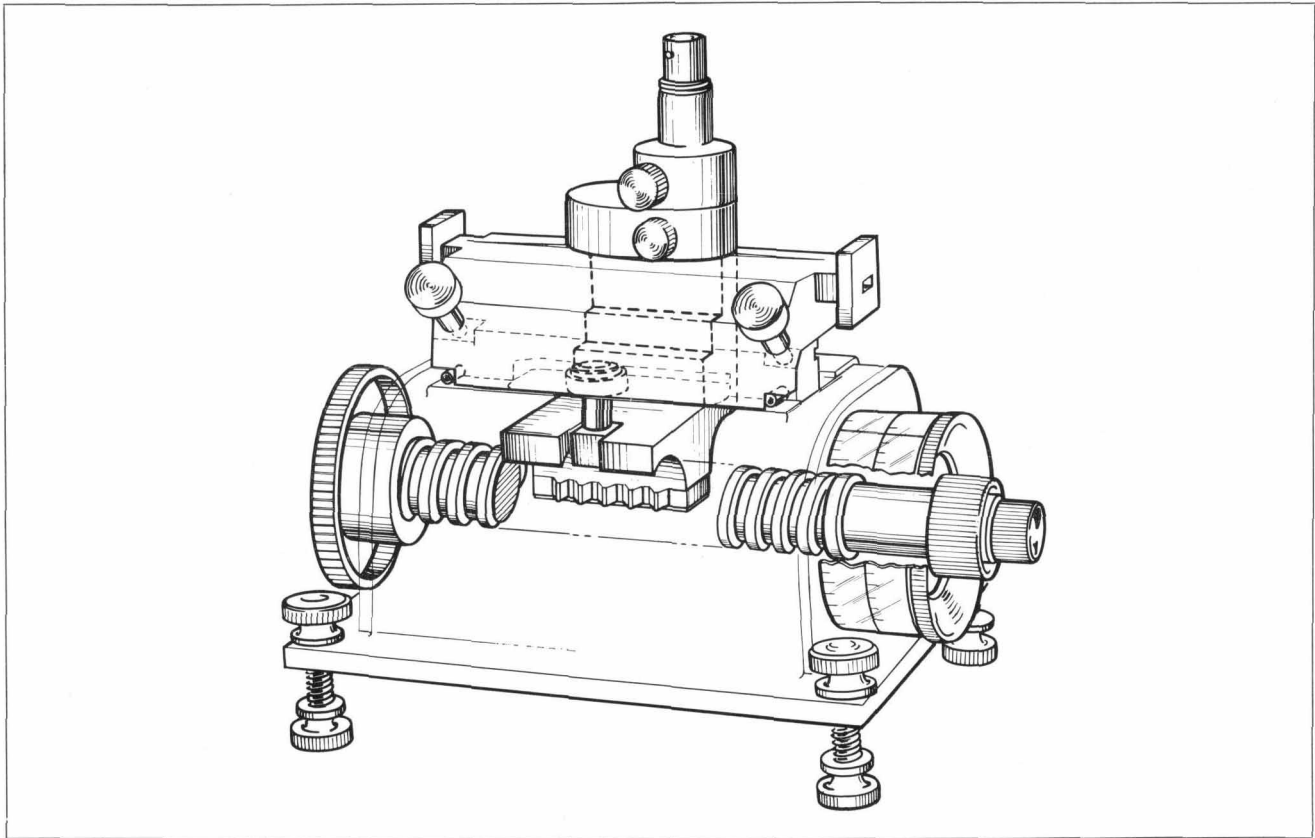

Fig. 4. Cutaway drawing showing how micrometric principle is incorporated in probe carriage design.

any desired section can be inserted in the carriage in a matter of seconds. A full waveguide range of overlap is provided between this and the lower frequency slotted line series to permit each series to have maximum usefulness.

### I. PROBE CARRIAGE

Because it operates in a frequency region where mechanical precision in slotted line equipment becomes increasingly important, the new probe carriage has been designed to give greater accuracy in probe positioning as well as greater accuracy in reading the probe position on a scale. The positioning mechanism is a precision lead screw and nut as shown in Fig. 4. The scale is similar to a micrometer head and consists of two drum dials carrying engraved divisions. The outer dial provides a

direct drive on the lead screw while the inner dial is geared down and is, in effect, a revolution counter. Ball bearings at each end of the carriage support the screw. Motion from the lead screw to the probe is imparted by a multi-thread nut section or traveler which is spring-loaded against the screw. A high order of precision is obtained for the screw and nut by forming the screw by grinding methods and by lapping the nut to the screw.

Vertical support for the probe holder is provided by a linear, horizontal bearing arrangement (not shown in illustration) which consists of precision balls running between precision horizontal grooves in two hardened surfaces located just below and behind the mounting plate for the slotted sections.

Besides giving high accuracy, the

design is such that it has no detectable backlash. The micrometer knobs are pinned to the lead screw shaft and thus provide a direct drive. The traveler nut is spring-loaded against the lead screw, while the weight of the probe holder and probe is completely absorbed by the linear bearing arrangement described previously. The screw thus has to supply only the force necessary to move the probe holder horizontally on its linear ball race.

The micrometer head at the right end of the carriage is calibrated in centimeters and can be read to within at least two-thousandths of a centimeter of probe travel (two-thousandths of a wavelength at 30 kmc). The micrometer scale is arranged so that it reads the distance of the probe directly from the right-hand flange surface of any of the slotted sections

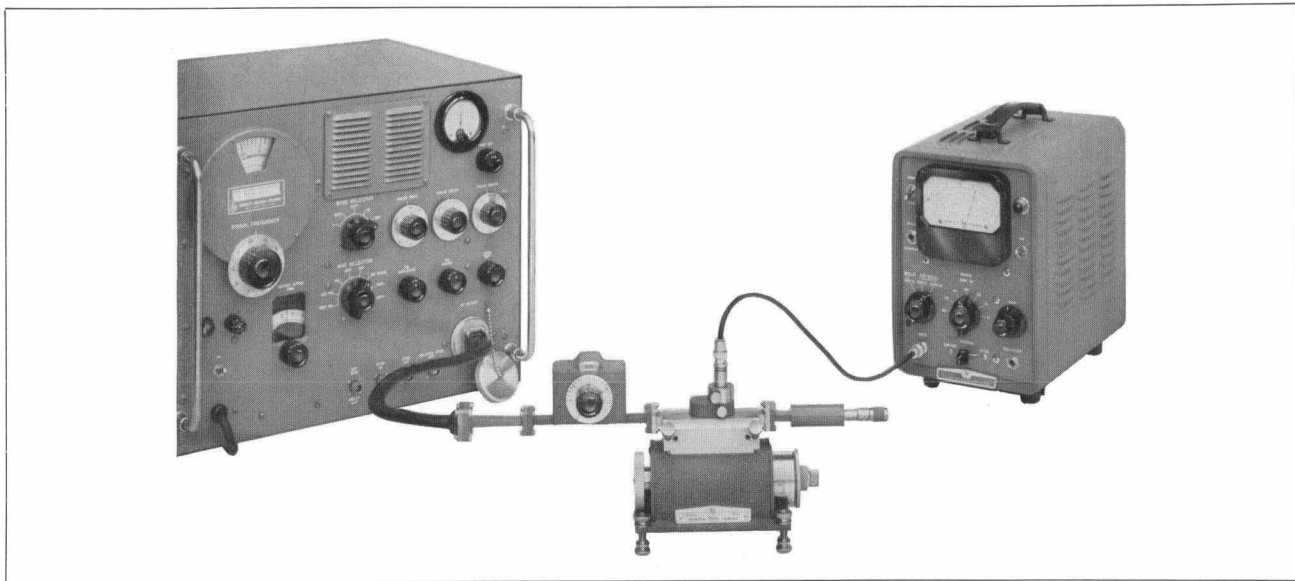

Fig. 5. New slotted line equipment used with -hp- 415B Standing Wave Indicator and 628A SHF Signal Generator.

designed for the probe, a feature of considerable assistance in most cases where the impedance at a point in the device attached to the slotted section is to be determined. A friction clutch on the micrometer head further permits the reading to be adjusted to any convenient reading at any point in its travel.

The probe position can be adjusted with either the right or left hand by means of the large slow-motion knobs at the ends of the carriage. In addition, the smaller knobs at the right side of the carriage can be used to move the probe more rapidly. The total probe travel is 3.9 cm or about 1 wavelength at the lowest rated frequency of 12.4 kmc.

To secure rigidity and permanent accuracy for the complete carriage, the mechanism is incorporated into a heavy box-like aluminum casting with wide flanges around the bottom surfaces. Levelling screws are provided at the corners.

## II. SLOTTED SECTIONS

Like the *-hp-* lower frequency waveguide probe carriage, the new Model 814A carriage is designed to

accommodate several waveguide sizes in order to achieve greater equipment flexibility. At present slotted sections for the 12.4-18, 18-26.5, and 26.5-40 kmc ranges have been designed for use with the carriage.

The sections mount on the carriage in a very simple manner. Each of the sections is provided with a lip along its front edge and this lip seats against a precision plate along the top of the carriage. This arrangement positions the slotted section

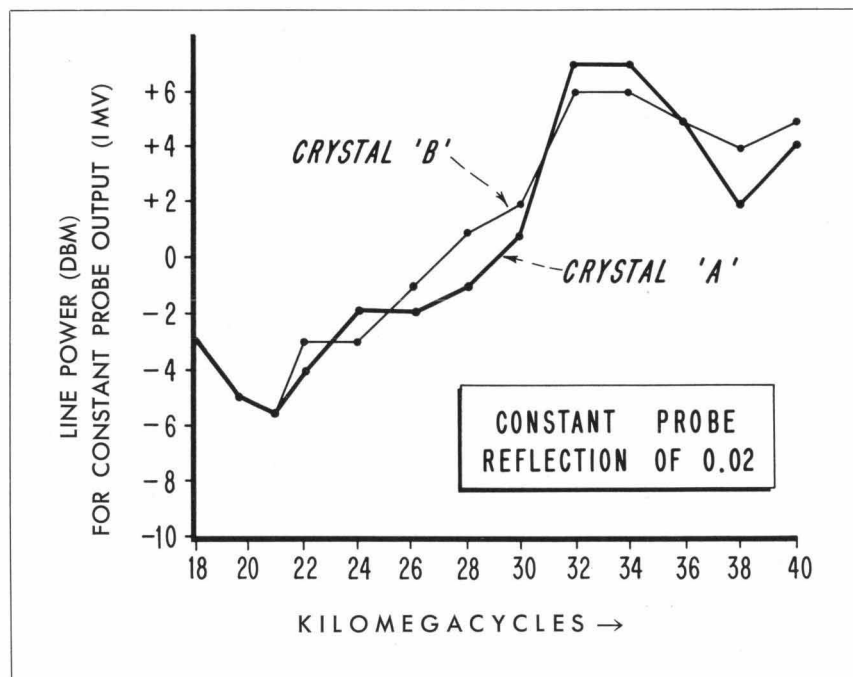

Fig. 6. Typical response curve of 446A broadband probe over 18-40 kmc range for two different crystals.

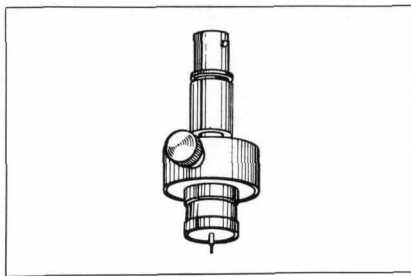

Fig. 7. New 446A broadband probe. Thumbscrew unlocks probe for adjusting antenna penetration.

positively and accurately, and it is then locked in place with two thumbscrews. Sections can thus be interchanged rapidly and conveniently.

Each of the sections is also arranged with a simple method for minimizing any slope error, although this adjustment is first made at the factory and normally need not again be adjusted. The adjustment is provided merely because the physical shape of a slotted section of waveguide prevents obtaining the same precision between the mounting surface and the axis of the guide that is achieved between the horizontal bearing race for the probe holder and the mounting plate for the slotted section.

The slope-adjusting mechanism consists of two shafts located in such a way that the shaft surfaces extend through the bottom of the section. The shafts are eccentrically mounted and are provided with end slots which extend through the front of the section. Slope adjustments thus consist merely of rotating one or the other of these shafts with a screwdriver.

The slotted sections are formed from tellurium copper, a material which has been shown by several investigations<sup>3</sup> to offer superior characteristics as a guide material in this range. Included among its desir-

<sup>3</sup>For example, Ralph D. Lending, *New Criteria for Microwave Component Surfaces*, Proceedings of the National Electronics Conference, Vol. XI, p. 391-401.

able properties is a high surface conductivity which, in contrast to silver in this range, remains high in the face of normal oxidation. A low residual VSWR for the sections is achieved by the use of tapered slots.

### III. 12-40 KMC UNTUNED PROBE

One of the most popular features of the *-hp-* lower frequency waveguide slotted line equipment has been that the sampling probe was designed as an untuned probe. Besides relieving the user of the inconvenience of making adjustments each time frequency was changed, this feature also meant that VSWR measurements were not susceptible to errors introduced when drifts in the frequency source during the measurement caused the probe to become detuned. At the same time the probe could be used over six waveguide bands and its efficiency was such that its output competed with or even bettered that of tuned probes.

The probe for the new slotted line equipment has also been designed as an untuned probe and operates over the full 12.4-40 kmc range. To accomplish this while keeping probe efficiency high, a 1N53 microwave crystal is modified by cutting away its outer coaxial shell in such a way as to expose its center pin and by reducing the diameter of the center pin itself. This modified crystal is then arranged in the probe in such a way that its center pin serves as the probe antenna. Through this arrangement the crystal is located sufficiently near the waveguide slot that the residual effects which give rise to the need for tuning methods are minimized. A d-c return path for the crystal is provided by a 100-ohm disc resistor which also serves to smooth the crystal response. Antenna penetration is adjustable by adjusting the height of the probe in its holder.

These considerations have resulted in an untuned probe which has high output and a relatively flat frequency response (Fig. 6). The output compares with that available from tuned probes, although in this frequency range individual crystals can affect the output by 6 db or more. The output drops off somewhat in the 30-40 kmc vicinity, in common with tuned probes.

### OTHER MILLIMETER WAVE EQUIPMENT

A number of other devices for the 12-40 kmc range are in production or under design, including mounts, attenuators, wavemeters, etc. These will be described in future issues.

### ACKNOWLEDGMENT

Acknowledgment is due consulting engineer Harold F. Elliott of Palo Alto, California, for the excellent probe carriage design.

—J. K. Hunton

#### SPECIFICATIONS

*-hp-*

#### MODEL 814A

#### UNIVERSAL PROBE CARRIAGE

Carriage: Mounts all *-hp-* 815A slotted sections.

Probe Required: *-hp-* 446A Untuned Probe.

Probe Travel: 3.9 centimeters.

Calibration: Metric. Vernier dial permits direct reading to 0.1 mm and interpolating to within 0.02 mm.

Accuracy: Residual VSWR less than 1.02. Slope errors can be eliminated by adjustment.

Adjustable Legs: Knurled thumb screws on all four carriage legs.

Size: 7" long, 4 1/4" wide, 5" high.

Price: \$225.00.

#### MODEL 815A

#### WAVEGUIDE SLOTTED SECTIONS

Model P815A: 12.4-18.0 kmc (0.622" x 0.311" I. D. guide); 5-19/64" overall length; \$200.00.

Model K815A: 18.0-26.5 kmc (0.420" x 0.170" I. D. guide); 5-19/64" overall length; \$200.00.

Model R815A: 26.5-40.0 kmc (0.280" x 0.140" I. D. guide); 5-19/64" overall length; \$200.00.

#### MODEL 446A

#### UNTUNED PROBE

Frequency Range: 12.4 to 40.0 kmc.

Detector: Modified 1N53 silicon diode.

Output Connector: Standard UG-1094/U connector.

Tuning: Untuned.

Price: \$145.00.

Prices f.o.b. Palo Alto, California.

Data subject to change without notice.